



## HOT ITEMS AND BRIGHT IDEAS

lighting and heating solutions



bright ideas

PROFESSIONAL PARASOL LIGHTS

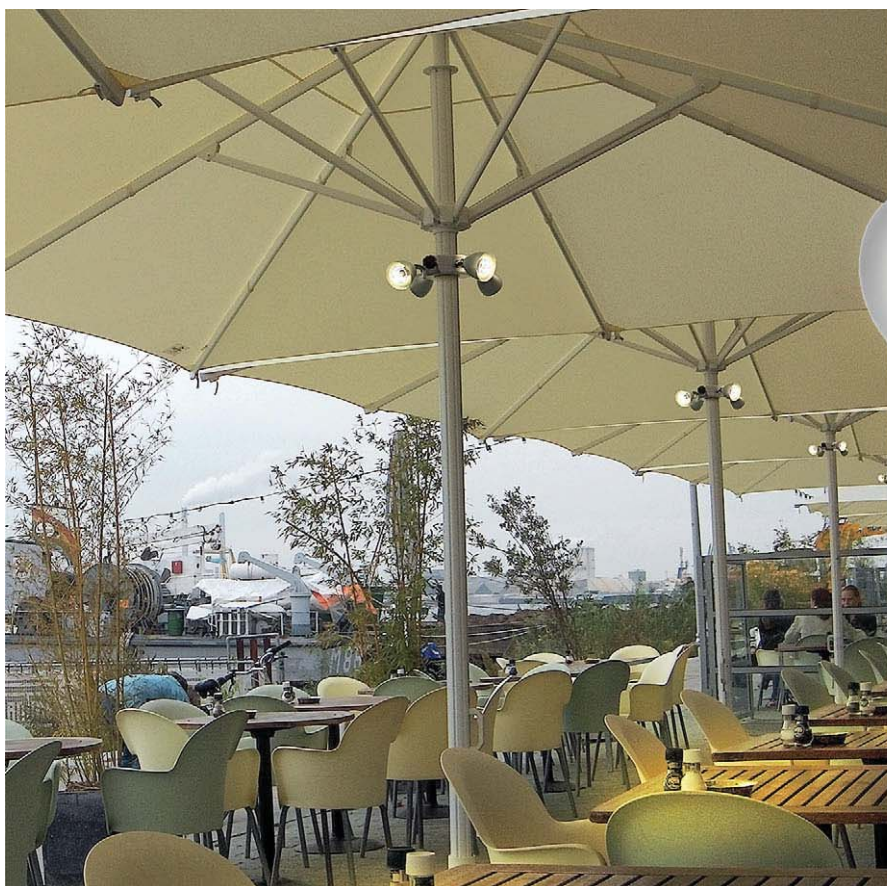

Spot »Naxos«

Alle unsere Schirmeleuchtungen sind stufenlos verstellbar, um je nach Wunsch eine direkte oder indirekte Lichtquelle zu schaffen. Die verschiedenen Designs sind jeweils in Weiß oder Titan erhältlich. Wahlweise bekommen Sie die Beleuchtungen mit Universalhalterung oder mit maßgeschneiderten Spezialeinsätzen für Tophoven Systeme. Eine Vorinstallation im Schirm ist in beiden Fällen nicht notwendig, das Nachrüsten ist ein „Kinderspiel“.

*All parasol lights are fully adjustable to get a direct or indirect light. The various designs are all available in white or titanium finish. All Models can be ordered with standard fittings for various pole diameters or special Tophoven-fittings. An electric installation inside the parasol is possible but not required.*

*Al onze parasolverlichtingen zijn traploos te verstellen zodat alle gewenste standen kunnen worden bereikt, zowel directe als indirecte verlichting. Alle modellen zijn zowel in wit als titaan te verkrijgen. U heeft keuze uit modellen met universele montageklemmen of speciale op maat gemaakte uitvoering voor Tophoven parasols. Een stroom-voorbereiding in de parasol is bij beide modellen niet meer nodig, het installeren is zeer eenvoudig.*



**Licht am Mast 4-fach mit Spot**

4 spotlights attached to the mast  
4 spots voor om de mast



Spot »Mykonos«



Spot »Rhodos«



Spot »Helios«

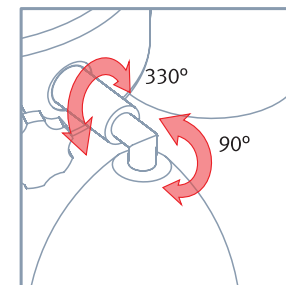

für ø 45-85 mm  
for ø 45-85 mm  
voor ø 45-85 mm

Artikel-Nr. item-No. artikel-nr.

Titan titanium Titaan

Spot »Naxos« 9105008

Spot »Mykonos« 9105009

Spot »Rhodos« 9105010

Spot »Helios« 9105011

Weiß white Wit

Spot »Naxos« 9105027

Spot »Mykonos« 9105030

Spot »Rhodos« 9105031

Spot »Helios« 9105032

Alle Schirmbeleuchtungen sind mit folgenden Verbindungsleitungen erhältlich: 2.500 / 5.000 / 10.000 mm - Sondermaße auf Anfrage.

All parasol lights are available with the following wirings: 2.500 / 5.000 / 10.000 mm - special wirings on demand.

Alle parasolverlichtingen zijn met volgende verbindingskabels leverbaar: 2.500 / 5.000 / 10.000 mm - speciale maten op aanvraag.

 **am Mast**  
mounted on a mast  
om de mast

 4x 50 W / GU10

 **Titan / Weiß**  
titanium / white  
Titaan / Wit

 230 V

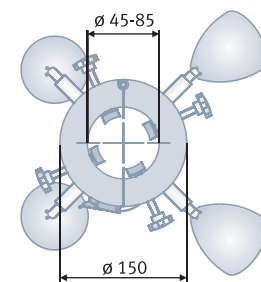
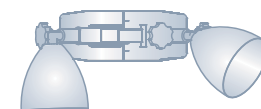

# hot items

## PROFESSIONAL OUTDOOR HEATERS



### SOLAMAGIC® 1400



**Wand, Decke, Stativ**  
wall, ceiling, stand  
wand, plafond, statief



**1x 1.400 W / HeLeN**



**Titan / Weiß**  
titanium / white  
Titaan / Wit



**bis 12 m<sup>2</sup>**  
up to 12 m<sup>2</sup>  
tot 12 m<sup>2</sup>



**230 V / 1-fasig**  
230 V / 1-phase  
230 V / 1-fase

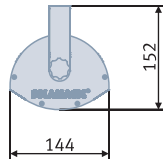
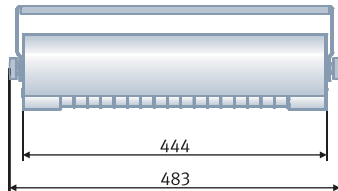

Artikel-Nr. item-No. Artikel-nr.

**Titan**  
titanium Titaan **9100002**

**Weiß**  
white Wit **9100000**

### SOLAMAGIC® 1400

#### Wärmestrahler mit Sprossen- halterung

Heater and bar attachment  
Heater met baleinbevestiging



**am Schirm, etc.**  
on parasol etc.  
aan de parasol



**1x 1.400 W / HeLeN**



**Titan / Weiß**  
titanium / white  
Titaan / Wit



**bis 12 m<sup>2</sup>**  
up to 12 m<sup>2</sup>  
tot 12 m<sup>2</sup>



**230 V / 1-fasig**  
230 V / 1-phase  
230 V / 1-fase

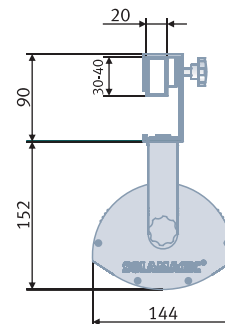

Artikel-Nr. item-No. Artikel-nr.

**Titan**  
titanium Titaan **9100018**

**Weiß**  
white Wit **9100020**

Alle Heizstrahler sind mit folgenden Verbindungs-  
leitungen erhältlich: 2.500 / 5.000 / 10.000 mm,  
Sondermaße auf Anfrage.

All heaters are available with the following  
wirings: 2.500 / 5.000 / 10.000 mm,  
special wirings on demand.

Alle heaters zijn met volgende verbindings-  
kabels leverbaar: 2.500 / 5.000 / 10.000 mm,  
speciale maten op aanvraag.

### SOLAMAGIC®



#### Windschutz-Steckhalterung

Wind shield mounted  
Terrasscherm-montagekleem



**am Windschutz**  
on wind shield  
aan terrascherm



**Titan / Weiß**  
titanium / white  
Titaan / Wit

max. Aufsteckmaß 50 mm  
max. plug-in length 50 mm  
max. breedte 50 mm

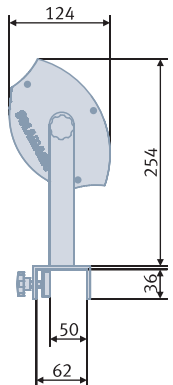

Artikel-Nr. item-No. Artikel-nr.

**Titan**  
titanium Titaan **9100025**

**Weiß**  
white Wit **9100026**



PROFESSIONELLE AUSSENBEREICHS-HEIZER

heiße teile

Mit unseren effektiv wirkenden Heizsystemen wird es nicht nur Ihnen warm ums Herz. Denn für alle unsere Schirme und Windschutzsysteme gibt es Heizstrahler, die je nach Bedarf montiert, ausgerichtet und eingestellt werden können.

*Our effective heating systems won't only warm your heart. For all our umbrellas and windscreens, there are heaters which can be fitted, directed and installed according to your needs.*

*Met onze effectief werkende verwarmingssystemen is het altijd aangenaam warm. Voor al onze parasols en terrasschermen hebben we heaters welke naar uw wens kunnen worden gemonteerd, uitgericht en ingesteld.*



*Equipped with unique PHILIPS HeLeN technology.  
Uitgerust met Phillips HeLeN technologie.*



# keep your guests warm







## SOLAMAGIC® 1400

### Masthalterung mit 2 Wärmestrahlern

Mast-mounted  
with 2 heaters  
Mastbevestiging  
met 2 heaters



-  **am Mast**  
mounted on a mast  
om de mast
-  **Titan / Weiß**  
titanium / white  
Titaan / Wit
-  **2x 1.400 W / HeLeN**
-  **montageabhängig**  
depending on the assembly  
montageafhankelijk
-  **230 V / 1-fasig**  
230 V / 1-phase  
230 V / 1-fase

für ø 45-85 mm  
for ø 45-85 mm  
voor ø 45-85 mm

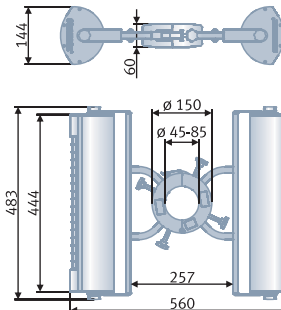

Alle Heizstrahler sind mit folgenden Verbindungsleitungen erhältlich:  
2.500 / 5.000 / 10.000 mm,  
Sondermaße auf Anfrage.

All heaters are available with the following wirings:  
2.500 / 5.000 / 10.000 mm,  
special wirings on demand.

Alle heaters zijn met volgende verbindingskabels leverbaar:  
2.500 / 5.000 / 10.000 mm,  
speciale maten op aanvraag.

Artikel-Nr. item-No. Artikel-nr.

Titan titanium Titaan **9100121**

Weiß white Wit **9100122**







## SOLAMAGIC® 1400

### Masthalterung mit 4 Wärmestrahlern

Mast-mounted  
with 4 heaters  
Mastbevestiging  
met 4 heaters



-  **am Mast**  
mounted on a mast  
om de mast
-  **Titan / Weiß**  
titanium / white  
Titaan / Wit
-  **4x 1.400 W / HeLeN**
-  **montageabhängig**  
depending on the assembly  
montageafhankelijk
-  **230 V / 1-fasig**  
230 V / 1-phase  
230 V / 1-fase

für ø 45-85 mm  
for ø 45-85 mm  
voor ø 45-85 mm

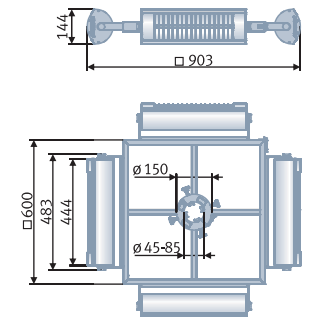

Artikel-Nr. item-No. Artikel-nr.

Titan titanium Titaan **9100123**

Weiß white Wit **9100124**





# halten sie sich ihre gäste warm

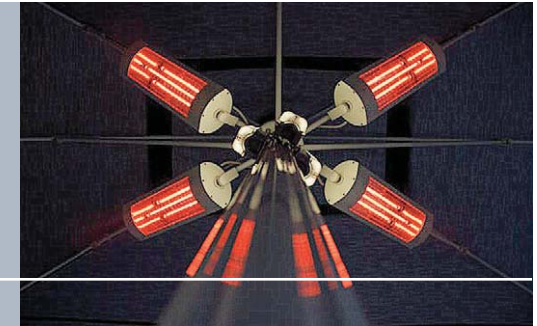

JEDE MENGE WÄRMSTE VORTEILE

- keine Aufheizphase, Wärme ist beim Einschalten sofort verfügbar
- Effizienz durch gezielte Wärmeabstrahlung
- die Wärme kann nicht vom Wind verweht werden
- einfachste Installation
- geräusch- und geruchlos
- 60 % Kostenersparnis gegenüber vergleichbaren Gasheizsystemen, 30 % Kostenersparnis gegenüber herkömmlichen Elektroheizungen
- spritzwassergeschützt
- flexible Positionierung (Wand- / Deckenmontage sowie über Stativ)
- individuelle Farbgestaltung möglich
- durch formschönes und kompaktes Design in jedes gastronomische Ambiente integrierbar
- längere Öffnungszeiten des Außenbereichs
- mediterranes Flair durch rötliches Licht

## LOTS OF WARMLY WELCOMED BENEFITS

*no warming-up phase, as heat is immediately available when switching on the appliance*

*high efficiency through targeted heat radiation*

*heat cannot be blown away by a draught*

*extremely simple installation*

*noiseless and odour-free*

*60 % cost savings compared to comparable gas heating systems, 30 % cost savings compared to conventional types of electric heating systems*

*splash-water protected*

*flexible mounting onto a wall, ceiling or structure or on a tripod*

*colour variations possible*

*can be integrated into any ambience with its shapely and compact design*

*reddish glow generates Mediterranean flair*

*geen opwarmperiode, warmte komt direct bij inschakelen vrij*

*efficiënt door gedeelde warmte uitstraling*

*warmte kan niet door de wind worden weggewaaid*

*eenvoudige montage*

*geruis- en reukloos*

*60 % kostenbesparing ten opzichte van vergelijkbare gasheaters, 30 % kostenbesparing ten opzichte van conventionele elektrische heaters*

*spat-waterdicht*

## VELE WARME VOORDELEN

*flexibele positionering (wand-, plafondmontage alsmede op een statief)*

*kleurvariaties mogelijk*

*door zijn elegante vorm en compacte design in alle gastronomie te integreren*

*verlenging van het terrasseizoen*

*mediterrane sfeer door zijn warme rode licht*





**HOT ITEMS AND  
BRIGHT IDEAS**

| **SOLAMAGIC®** for



Weihersfeld 1  
41379 Brüggen

Telefon +49 (0)21 63 - 95 24 24  
Telefax +49 (0)21 63 - 95 24 25

info@tophoven-gmbh.de  
[www.tophoven-gmbh.de](http://www.tophoven-gmbh.de)

Eine Kooperation mit  
a cooperation with | Een coöperatie met



■ ■ ■ Made in Germany